

Universal network version stepless adjustment thermostat



■ PRODUCT OVERVIEW

The thermostat uses liquid crystal display mode, simple fashion. Adopt international advanced microcomputer control chip precision control, through the inside of the thermostat, precise NTC sensor to detect the indoor temperature, automatically adjust the cooling and heating air volume or switch and auxiliary heat and water valve, quickly reaching users set temperature.

This series of thermostats is designed according to the safety standard, which meets the national electrical safety standard. It is suitable for indoor temperature control of industry, commercial and family room, The distance between the thermostat and the connecting line of the unit is less than 30 meters. **GND and 0-10V are weak current speed regulation signals, which must be isolated from strong currents during wiring, otherwise the thermostat or the unit may be damaged!**

■ SPECIFICATION

- Power: switching power
AC90~250V 50/60HZ
- Power consumption: <2W
- Display components: LCD screen
Temperature sensor: NTC sensor
- Temperature display resolution: 0.1°C
- Control accuracy: ± 1°C
- Display temperature range: 0 ~ 60°C

- Temperature adjustment range: 5 ~ 45°C
- Ambient humidity: 5 ~ 95RH%, not dew
- Relay load current:
perceptual load <2A/AC250V
resistive load <5A/AC250V
- Terminals: 1×2.5 mm²
- Button type: TACT button
- Housing: ABS high flame retardant material
- Dimension: 86×86×10mm
- Mounting aperture: 60mm

■ MAJOR FUNCTION

- Slim panel design(10mm)
- High texture acrylic panel
- COOL / HEAT / FAN / AUTO MODE
- 5-speed fan Manual adjustment
- PI stepless fan speed adjustment (auto fan speed)
- A variety of parameter setting function
- Temperature deviation correction function
- With EEP memory backup(option)
- With low temperature antifreeze function
- Timer ON/OFF function (countdown)
- RS485 communication function (Modbus RTU)

■ PACKAGE CONTENTS

- Manual 1PCS
- Screw 2PCS

■ SIZE

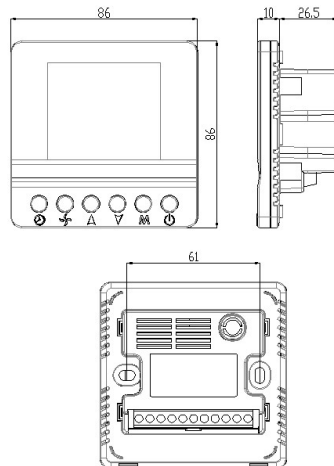

■ INSTALLATION INSTRUCTIONS

- Make sure to turn off the power before the installation, in order to avoid risks of electric shock, or damages to the system components.
- Select the correct installation location, and do not install the product under the direct sunlight or in damp location.
- The rear panel should be screwed to the wall switch box.
- Refer to the wiring diagram, correctly connect the power supply, electric valves and DC motor.

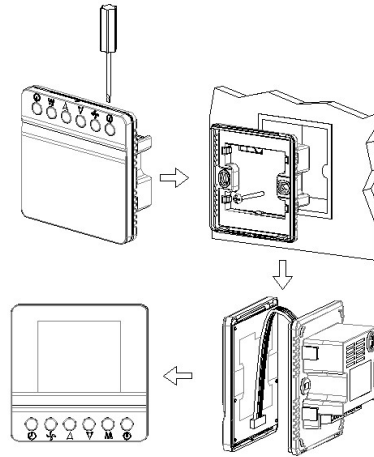

■ KEY INSTRUCTIONS

- ⏻: On/Off
- M: Function mode
- 🌀: Fan-speed
- 🕒: Clock adjustment
- ▲ / ▼: Increase/ Decrease

■ OPERATION INSTRUCTIONS

- **ON/OFF operation:**
 - Make sure the power supply and wiring are correct before starting up.
 - Power-on: press “⏻” key for power on the thermostat to show the room temperature.
 - Power-off: press “⏻” key for power off the thermostat, turn off the fan and valve.
- **Mode adjustment:**
 - Under power on, press “M” key to change on

controller function mode.

- Two pipes: The controller change function mode : cool→heat→fan→cool.
- Four pipes: The controller change function mode : cool→heat→fan→Auto→cool.
- Mode setting will be stored in the memory.
- **Temperature adjustment:**
 - Under power on, press “▲” “▼” key to adjust the setting temperature point.
 - Setting point adjustment maximum range: 5 ~ 45 °C step 1 °C .The upper and lower temperature limits are determined by the internal setting items 2 and 3, and the upper limit can not be lower than the lower limit.
 - The adjusted setting temperature point will be memorized.
- **FAN speed adjustment:**
 - Under cooling or Heating mode :
Press “🌀” key to select the fan speed.
1st🌀→2nd🌀(flashing)→3rd🌀→4th🌀(flashing)→5th🌀→AUTO→1st🌀.
 - When function-mode as “fan” only:
Press “🌀” key to select the fan speed.
1st🌀→2nd🌀(flashing)→3rd🌀→4th🌀(flashing)→5th🌀→1st🌀.
 - Fan speed setting will be stored in the memory.
- **Panel lock and unlock:**
 - In the power-on state, in the unlocked state, long press “▲” and “▼” keys for 3 seconds, the thermostat is locked and the “🔒” icon is displayed.
 - In the locked state, long press “▲” and “▼” keys for 3 seconds, the thermostat is unlocked, and the display “🔒” icon disappears.
 - In the power-on state, when the internal setting item P13 is set to “2” / “3”, the thermostat is locked, showing the “” icon and the thermostat IP address;
 - Long press “▲” and “▼” keys to lock and respond in parallel with P13 lock, P13 has higher priority than long press “▲” and “▼” keys to lock;
 - The locked state will be stored in the memory. When the thermostat is locked, you can only press “⏻” key or long press “M” key to modify the internal setting parameters, other keys are invalid.
- **Timer ON/OFF function:**
 - Under power on, press “🕒” key, shutdown timer

countdown set.

- Under power off,press "⊖" key, boot timer countdown set.
- Press "▲" key once to increase 0.5, press "▼" key to decrease 0.5. Range: 0~24 hours.
- When set to 0, the countdown is invalid.
- After setting 3s, confirm automatically.
- Timing countdown time is not will be memorized.

● **Sensor failure:**

- When the sensor is short-circuited or the room temperature exceeds 60°C, the LCD will display "HI" abnormal.
- When the sensor is open or the room temperature is below 0°C, the LCD will display "LO" abnormal.
- When a sensor abnormality occurs, only display prompt function.

■ **Option setting**

- In the power-on state, long press the "" key to enter the password input interface, display "000" in the temperature display position, and press the "▲" "▼" "M"keys to increase the hundred, ten, and single digits, respectively. 0-9, A, b, C, d, E, F cycle, password "902", press "" key to confirm, the password is wrong or no operation within 20 seconds to return to the main interface, the password is correct to enter the parameter setting interface
- Each time you press the "M" key or "▲" "▼" key, it will re-time 20 seconds; within 20 seconds, no key is pressed to return to the power-on state, confirm the new option setting value, otherwise exit without changing the parameter setting; after the parameter modification is confirmed, press the "↵" key to exit or automatically exit after 20 seconds of no operation, and the parameter value is written into the memory.

• The options are set as follows:

Item	Instruction	Defaults
1	RS485 IP setting : Range 1~31 step:1	01
2	Set upper limits Temp.: Range: lower limit ~ 45 step: 1	30°C
3	Set lower limits Temp.: Range: 5 ~ upper limit step: 1	10°C

4	Heating setting : 0 : No 1 : Yes 2 : Single heat mode	1 (read-only)
5	Mode selection : 0 : Two pipe 1 : Two pipe+Auxiliary heat 2 : Four pipe	0
6	Temperature calibration setting(offset) : (-5°C~5°C) step:0.1°C	0°C
7	Diff. temp. setting : (1°C~5°C) step:0.5°C	1°C
8	Fan-speed logic : 0 : Fan 1 : Stop the fan	1
9	After power on status : 0 : Off state 1 : On state 2 : Restore the state before the power outage	0
10	Anti-freeze function: 0 : No 1 : Yes	1
11	Sensor selection : 0 : Inner sensor 1 : Remote sensor	0 (read-only)
12	Reserved	1 (read-only)
13	RS485 authority: 0: RS485 read-only, thermostat modification 1: RS485 On/Off, thermostat modification 2: RS485 modification, thermostat read-only 3: RS485 modification, thermostat On/Off 4: RS485 modification, thermostat modification	4
14	Display selection 0 : Display room temperature 1 : Display set temperature	0
15	PI sampling time Range:(1~600S) STEP : 1 S	60
16	Kp (proportional control factor) Range:(1~100) STEP : 1	10
17	Fan maximum gears number setting : Range : 3~5 STEP : 1	5
18	1st fan speed voltage Fan1 : Range:0≤set voltage < Fan2, step: 1	200
19	2nd fan speed voltage Fan2: Range:Fan1≤set voltage < Fan3 step: 1	400
20	3rd fan speed voltage Fan3: Range:Fan2≤set voltage < Fan4, step: 1	600
21	4th fan speed voltage Fan4: Range:Fan3≤set voltage < Fan5, step: 1	800
22	5th fan speed voltage Fan5: Range:Fan4≤set voltage≤10,step: 1	1000
23	Restore factory settings 0 : NO 1 : Yes	0

■ **WIRING DIAGRAM**

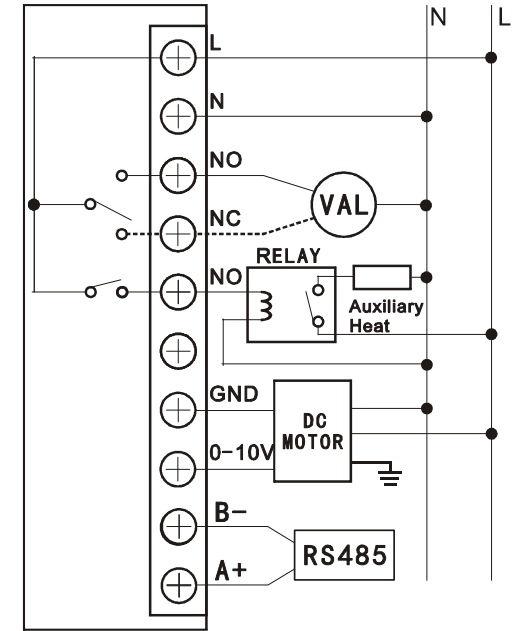
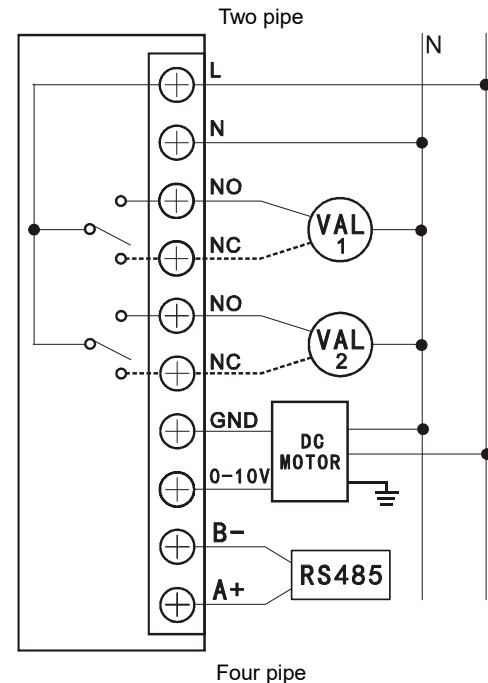
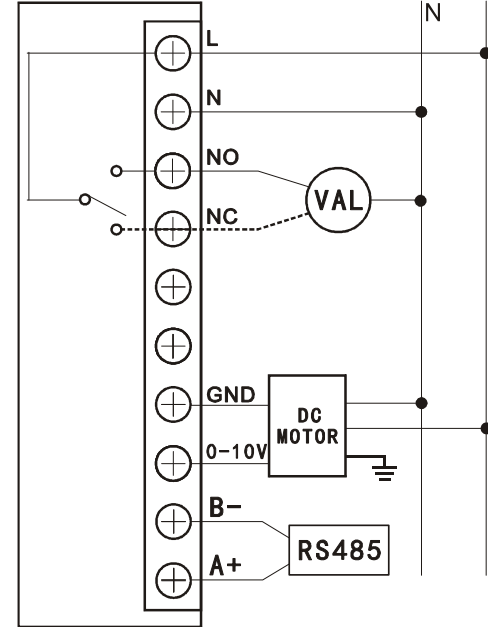

Two pipe+Auxiliary heat

■ **AFTER-SALE PRODUCT SERVICE**

- The warranty period of this product is based on the purchase contract.
- After the warranty or non quality problems caused by the after-sales service, will charge a certain fee

THANKS!

Thank you very much for your selection of the company's products, please read the instructions carefully before using this product

In to provide you with quality products at the same time, we will also provide a sound technical support and after-sales service, you can also log on to our company's website and contact us

Dunham-Bush (China) Co., Ltd
 Tel: + 86 535 7397888
 Fax: + 86 535 7397999
 Address:No. 1 Dunham-Bush Road, Laishan District, Yantai Shandong,China
 Website: <http://www.dunham-bush.com.cn>